



Concrete Applications



Steel Applications

Not to scale.

MATERIAL SPECIFICATIONS

Pin - Galvanized Carbon Steel

Washer - Polypropylene

PRODUCT DESCRIPTION

The Thermal-Grip[®] Insulation Pin is a large 2.25" diameter washer head fastener with pins available to attach insulation to concrete/CMU or 14-18 gauge steel studs. Anchor pins are available in lengths from 1" to 6". Use with Thermal-Grip IP Insulation Fastening Tools for rapid attachment.

PRODUCT SPECIFICATIONS

Basis of Design: Thermal-Grip[®] Insulation Fastening Tool as manufactured by TRUFAST[®] Walls.

Application: The IP50D tool is a concrete pinner tool designed to attach insulation to a concrete wall. Gas-actuated insulation fasteners. No screws or adhesives required.

- a. Permanently attaches insulation with a flush finish.
- b. For use attaching all types of rigid insulation including XPS, EPS, polyisocyanurate and mineral wool.

Description: 2-1/4" (57mm) diameter, solid plastic, to reduce thermal bridging

Lengths: Anchor lengths available for insulation 1" - 6" thick

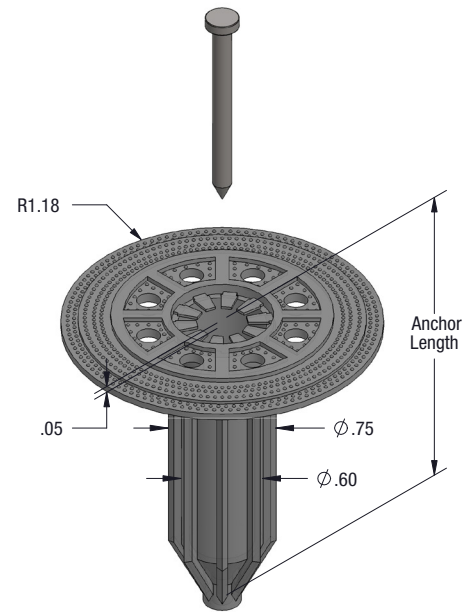

PRODUCT SELECTION

Part No.	Application	Anchor Length	Pkg. Qty.	Pkg. Wt.
TGIP-1000	Concrete	1" (25mm)	500 pcs.	14 lbs.
TGIP-1500	Concrete	1.5" (38mm)	500 pcs.	14 lbs.
TGIP-2000	Concrete	2" (51mm)	500 pcs.	15 lbs.
TGIP-2500	Concrete	2.5" (64mm)	500 pcs.	15 lbs.
TGIP-3000	Concrete	3" (76mm)	500 pcs.	17 lbs.
TGIP-4000	Concrete	4" (102mm)	500 pcs.	17 lbs.
TGIP-5000	Concrete	5" (127mm)	250 pcs.	12 lbs.
TGIP-6000	Concrete	6" (152mm)	250 pcs.	12 lbs.
TGIP-ST-1000	Steel	1" (25mm)	500 pcs.	14 lbs.
TGIP-ST-1500	Steel	1.5" (38mm)	500 pcs.	14 lbs.
TGIP-ST-2000	Steel	2" (51mm)	500 pcs.	15 lbs.
TGIP-ST-2500	Steel	2.5" (64mm)	500 pcs.	15 lbs.
TGIP-ST-3000	Steel	3" (76mm)	500 pcs.	17 lbs.
TGIP-ST-4000	Steel	4" (102mm)	500 pcs.	17 lbs.
TGIP-ST-5000	Steel	5" (127mm)	250 pcs.	12 lbs.
TGIP-ST-6000	Steel	6" (152mm)	250 pcs.	12 lbs.

APPROPRIATE ACCESSORIES

Thermal-Grip[®] IP Insulation Fastening Tools to rapidly attach insulation to concrete, masonry, and tilt up/ precast walls



IP40D
Low-Mid Range PSI
Use with Insulation Pins 1" - 4"



IP50D
Mid-High Range PSI
Use with Insulation Pins 1.5" - 6"

A-W-IPF



Pinner Tool
Fuel Cell

PRODUCT FEATURES

- Anchor lengths available from 1" to 6" to match insulation thickness
- Large 2.25" diameter washer head secures insulation
- Pins (TGIP) available for attaching insulation to concrete/CMU
- Pins (TGIP-ST) available for attaching insulation to 14-18 gauge steel studs
- Can be used to attach EPS, XPS, ISO, and mineral wool insulation



INSTALLATION GUIDELINES

- Ensure fuel cell and battery are properly inserted into the tool.
- Place fastener on end of barrel.
- Push the fastener into the insulation to release safety.
- Once the safety is released, pull trigger to install the fastener.



Bulletin No. TFW-23112

DISCLAIMER

The information provided here is subject to change without notice. The performance specifications published in this TRUFAST[®] Walls product literature are based on controlled laboratory tests and are intended as a guideline only. They are not guaranteed in any way by the ALTENLOH, BRINCK & CO. US, INC., since building

design, engineering, and construction, including workmanship and materials, are beyond the control of the manufacturer. The manufacturer recommends that pull-out tests be conducted to verify the substrate provides adequate pull-out values.