

POWERLAGS®

FOR LOG HOME & TIMBER FRAME CONSTRUCTION



SPAX® PowerLags® bring a new level of fastening efficiency and reliability to log home and timber frame construction. Engineered specifically for these demanding wood-to-wood structural applications, SPAX PowerLags feature patented thread serrations that eliminate pre-drilling and dramatically increases installation speed. SPAX PowerLags are also code listed and load rated, so you can be assured of the reliability of the assembly. Available in two head styles for job matched performance and aesthetics.

PRODUCT FEATURES

- No pre-drilling required.
- Building code recognized ICC-ES ESR-1782
- Low profile, large diameter head designs provide exceptional draw down of even rogue logs.
- Deep T-Star Drive provides superior bit engagement and allows for easy backout of the fastener if necessary when the head is countersunk.
- Proprietary coating provides excellent corrosion resistance and prevents staining wet logs. (Not meant for exterior exposure to rain.)
- Fastener length stamp on the head provides convenient identification without measuring and aids on-site inspections.
- German engineered thread technology; Made in U.S.A.
- Job-site friendly and weather-resistant packaging.

T-STAR PANCAKE HEAD

T-STAR WASHER HEAD



THREAD SERRATIONS

Patented thread serrations require up to 40% less driving torque to increase installation speed, while helping to prevent cracking in logs.

MADE IN U.S.A.



The Pancake Head offers the ultimate in flush or countersunk installation to help ensure a tight connection between logs.



The low-profile Washer Head offers a cleaner look than hex head fasteners in exposed applications.



SEE OUR COMPLETE OFFERING AT SPAX.US/PRODUCTS.



ENHANCED PRODUCTIVITY
STRONGER RESULTS
SATISFIED CUSTOMERS



T-STAR, Partial Thread
PANCAKE HEAD

PRODUCT SELECTION & SPECIFICATIONS

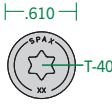
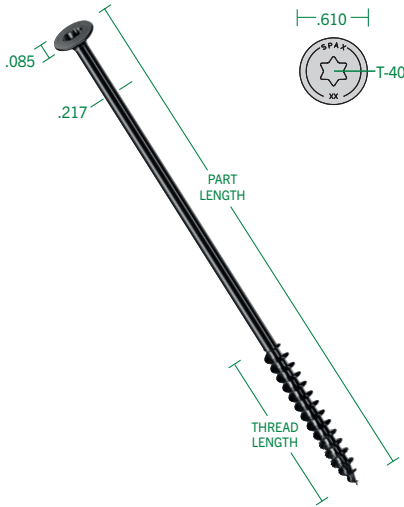

DIA. & LENGTH	COATING	DRIVE BIT	THREAD LENGTH	PART NO.	PKG. QTY. / TYPE	PALLET QTY.
5/16" x 4"	BLACK eCOAT	T-40	2.375"	3601770801000	250 / Pail	20,000
5/16" x 6"	BLACK eCOAT	T-40	2.375"	3601770801500	250 / Pail	20,000
5/16" x 8"	BLACK eCOAT	T-40	2.375"	3601770802000	250 / Pail	20,000
5/16" x 9"	BLACK eCOAT	T-40	2.375"	3601770802200	250 / Pail	15,000
5/16" x 10"	BLACK eCOAT	T-40	2.375"	3601770802500	250 / Pail	15,000
5/16" x 11"	BLACK eCOAT	T-40	2.375"	3601770802700	250 / Pail	15,000
5/16" x 12"	BLACK eCOAT	T-40	2.375"	3601770803000	250 / Pail	15,000
5/16" x 13"	BLACK eCOAT	T-40	2.375"	3601770803300	250 / Pail	7,500
5/16" x 14"	BLACK eCOAT	T-40	2.375"	3601770803500	250 / Pail	7,500
5/16" x 15"	BLACK eCOAT	T-40	2.375"	3601770803800	250 / Carton	7,500
5/16" x 16"	BLACK eCOAT	T-40	2.375"	3601770804000	250 / Carton	7,500

NOTE: One T-40 Driver Bit included in each package.



T-STAR, Partial Thread
WASHER HEAD

PRODUCT SELECTION & SPECIFICATIONS

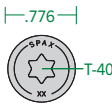
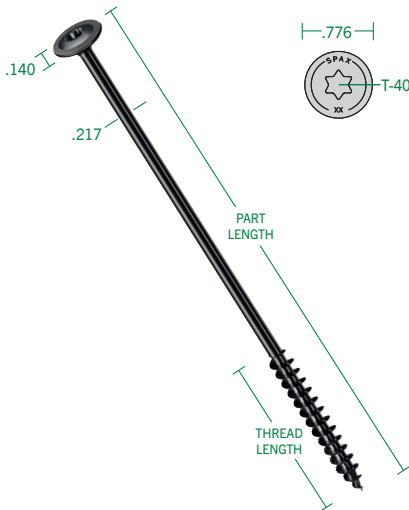

DIA. & LENGTH	COATING	DRIVE BIT	THREAD LENGTH	PART NO.	PKG. QTY. / TYPE	PALLET QTY.
5/16" x 6"	BLACK eCOAT	T-40	2.375"	3581770801500	250 / Pail	20,000
5/16" x 8"	BLACK eCOAT	T-40	2.375"	3581770802000	250 / Pail	20,000
5/16" x 9"	BLACK eCOAT	T-40	2.375"	3581770802200	250 / Pail	15,000
5/16" x 10"	BLACK eCOAT	T-40	2.375"	3581770802500	250 / Pail	15,000
5/16" x 11"	BLACK eCOAT	T-40	2.375"	3581770802700	250 / Pail	15,000
5/16" x 12"	BLACK eCOAT	T-40	2.375"	3581770803000	250 / Pail	15,000
5/16" x 13"	BLACK eCOAT	T-40	2.375"	3581770803300	250 / Pail	7,500
5/16" x 14"	BLACK eCOAT	T-40	2.375"	3581770803500	250 / Pail	7,500
5/16" x 15"	BLACK eCOAT	T-40	2.375"	3581770803800	250 / Carton	7,500
5/16" x 16"	BLACK eCOAT	T-40	2.375"	3581770804000	250 / Carton	7,500

NOTE: One T-40 Driver Bit included in each package.

PERFORMANCE SPECIFICATIONS Per ICC-ES Report No. ESR-1782

MEMBER TYPE (SPECIFIC GRAVITY) ¹	ALLOWABLE WITHDRAWAL (lbf. / in.) ^{2,3}	ALLOWABLE HEAD PULL-THROUGH (lbf) ^{2,4}	
		T-STAR PANCAKE HEAD	T-STAR WASHER HEAD
0.67	388	739	996
0.55	295	649	770
0.50	259	572	676
0.46	230	496	601
0.43	210	432	544
0.36	164	257	413
0.31	133	115	319

MATERIALS AND COATING: Carbon steel fasteners with a black eCoat for log homes and timber frame construction where fasteners are sealed from exterior weather and wet conditions.

- For wood species with an assigned specific gravity.
- Extrapolation to specific gravities greater than 0.67 or less than 0.31 is not permitted. Allowable loads for SPAX PowerLags® are based on ICC-ES Code Report ESR-1782. Use of SPAX® wood construction fastener in wood with a moisture content exceeding 19% either at time of fabrication or in service, is outside the scope of ICC-ES Code Report ESR-1782.
- Reference design withdrawal values are to be multiplied by the length of thread penetration into main member. Thread length includes tip.
- Reference design head pull-through values are for a member type where the minimum thickness is 1.5".

Allowable Steel Strength
 Bending Yield Strength: 150,000 psi
 Determined in accordance with ASTM F 1575 using minor thread diameter when fastener is tested in a threaded location.
 Tensile Strength: 1,459 lbf
 Shear Strength: 920 lbf
 Determined in accordance with NASM 1312:20 when fastener is tested in the transition (shank to thread) location.



ALTENLOH, BRINCK & CO. US, INC.
 2105 COUNTY ROAD 12C • BRYAN OH 43306 • Phone: 888-ABC-SPAX
 Email: sales@spax.us

